

Yamuna Machine Works Ltd.



For Textile Processing Machines

Regd. Office

D-17, Akurli Industrial Estate,
Kandivali (E), Mumbai - 400 101 INDIA
Phone : 91-22-28879920, 32564275,
32564275
Fax : 91-22-28875957

Factory

Plot No. 1302 / I, GIDC phase III,
Vapi - 396195 Dist. Valsad,
Gujarat, INDIA
Phone : 91-260-2401476
Fax : 91-260-2420488

Delhi

276, Mayur Vihar, Phase II,
Delhi - 110091 INDIA

Surat

204, Rajhans, Ring Road, Surat, INDIA

Ahmedabad

M/s Dharmshil Agencies
4th floor, Agrawal Complex, C.G. Road,
Ahmedabad - 380 009 INDIA

sales@yamunamachine.com
www.yamunamachine.com



COATING & TECHNICAL TEXTILE

A special ring to our engineering,
from singeing to finishing





COATING & TECHNICAL TEXTILE

COATING & TECHNICAL TEXTILE

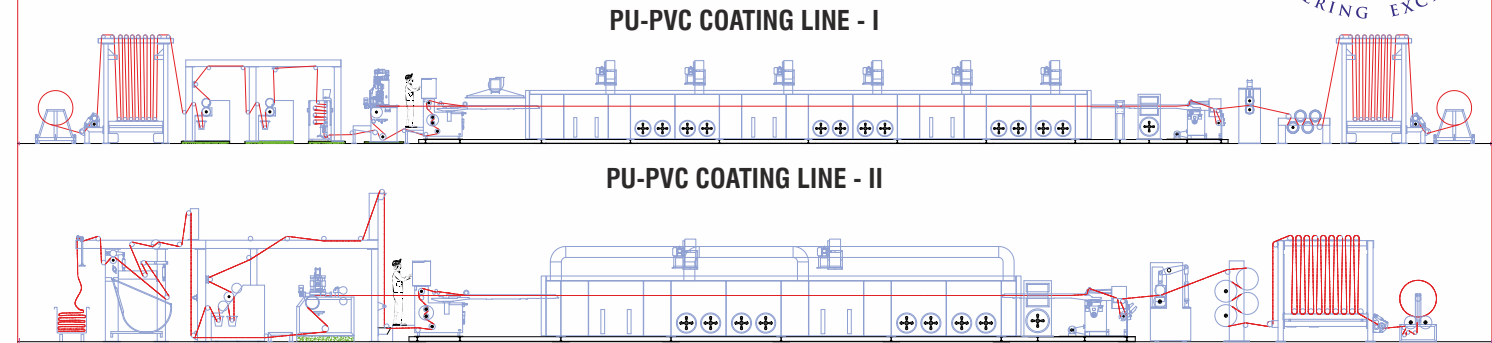
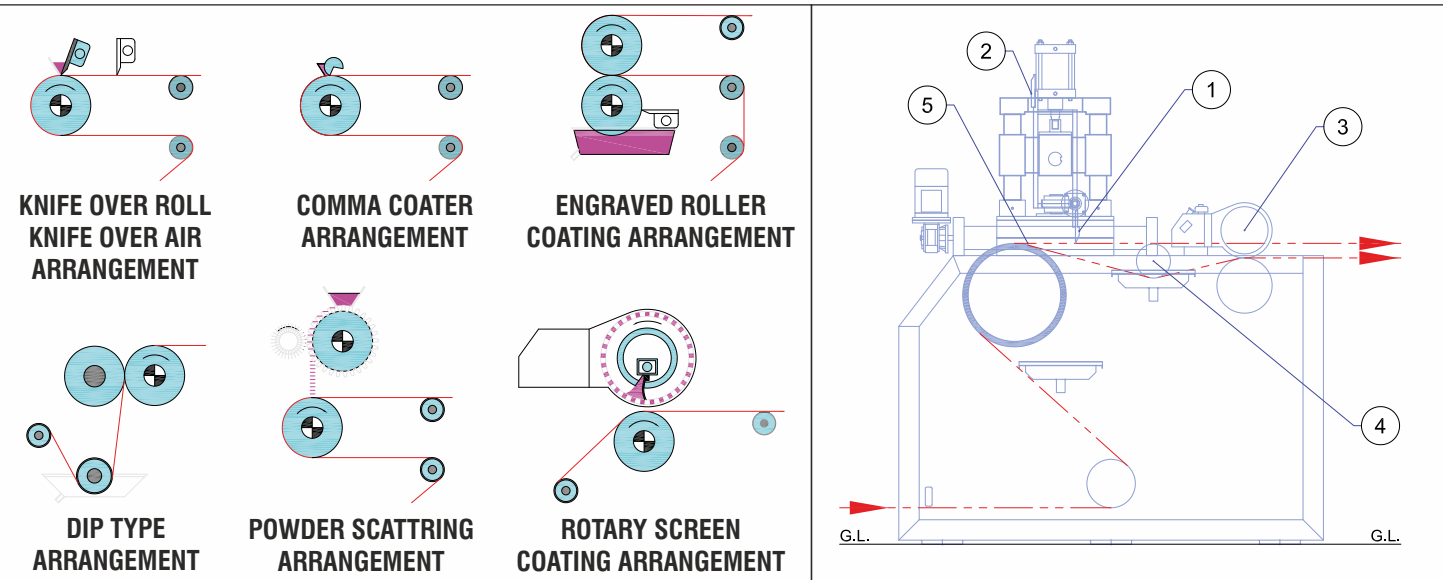

Technical Information

- Rollerface : 1600 - 4400mm
- Versatile and modular coating system to produce a wide range of products for tarpaulins, apparels, home textiles, floor coverings, rugs, artificial leather, blinds, pigment coatings, protective cloth, curtains, parachute fabrics, umbrella, sports wear, automotive application.
- Motorised adjustment of knife in vertical position - between knife and roller.
- Motorised angular adjustment of knife.
- Motorised adjustment of knife on horizontal position.
- Electronic scales for all axis. display of all setting / positions on digital displays.
- Micro - adjustment gears for gap setting.
- Pneumatic lifting for entire blade assembly synchronised with seam detection.
- Positive control for left and right side.
- Screen Printing single screen with pneumatic squeezing system.
- Engraving roller based coating systems.
- Application system by pipes, try or traversing type applicator with auto dosing system with pump.
- Foam generators with foam feeding system can be provided.
- Embossing / glossy Finish / Matt Finish device Heated chrome plated roller with hydraulic pressure to a rubber roller to achieve desired final finish on the coated material.



TWO STATION COATING LINE

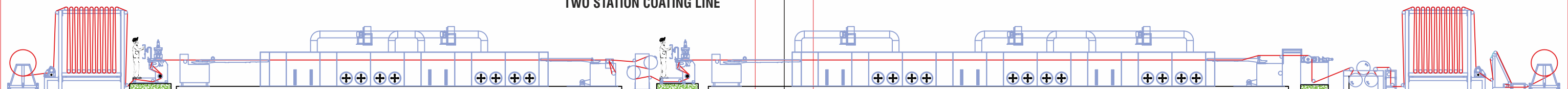

3 COAT PAPER LINE

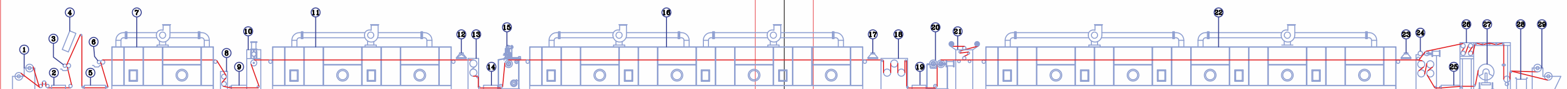

- | | | | | | |
|--------------------|--------------------------|---------------------------|--|---------------------------------|---|
| 1. UNWINDER | 6. PRINTING UNIT | 11. DRYER (6 Mtr.) | 16. DRYER (12 Mtr.) | 21. LAMINATOR UNIT | 26. PRODUCT COOLING DRUM (4 NOS.) |
| 2. PLATFORM | 7. 3 Mtr. DRYER | 12. HOOD | 17. HOOD | 22. DRYER (15 Mtr.) | 27. PAPER WINDER |
| 3. LACQUERING UNIT | 8. COOLING DRUM (2 NOS.) | 13. COOLING DRUM (2 NOS.) | 18. COOLING DRUM (3 NOS.) | 23. HOOD | 28. EDGE TRIMMER WITH DRUM & TRIM DISCHAGER |
| 4. RADIATOR | 9. PLATFORM | 14. PLATFORM | 19. PLATFORM | 24. PAPER COOLING DRUM (4 NOS.) | |
| 5. PLATFORM | 10. 1st COATING HEAD | 15. 2nd COATING HEAD | 20. 3rd COATING HEAD (GROW APPLICATOR) | 25. PLATFORM | |



BATHMAT & CARPETS

After tufting or weaving the carpet, there is must to do coating for following reasons:

- To get better dimension stability.
- To obtain tuft lock strength.
- Avoid damaging the carpet during installation and transportation.
- To impart a better finish and look.
- To get value addition in terms of possibility of applying various coating eg: Gel backing, felt backing, action backing etc.

Types of Coating:

- Gel backing
- Pre coating
- Two shot gel backing
- Felt/ action backing

Types of Chemicals can be used/ processed on our machines:

- Natural rubber
- Acrylic base compound
- All other water based and synthetic compounds.
- Styrene butadiene rubber latex
- EVA compound

Capable of developing customised and multipurpose coating lines for any type of carpets, mats and rugs SPECIAL DESIGN OF STENTER OVEN FOR back coating carpets/rug with temperature sensitive yarn. Separate heating source for top and bottom side air flow. This enables to regulate temperature separately in top and bottom side of the oven which enables the carpet to be finished with different temperatures of front (pile side) and back (coating side).

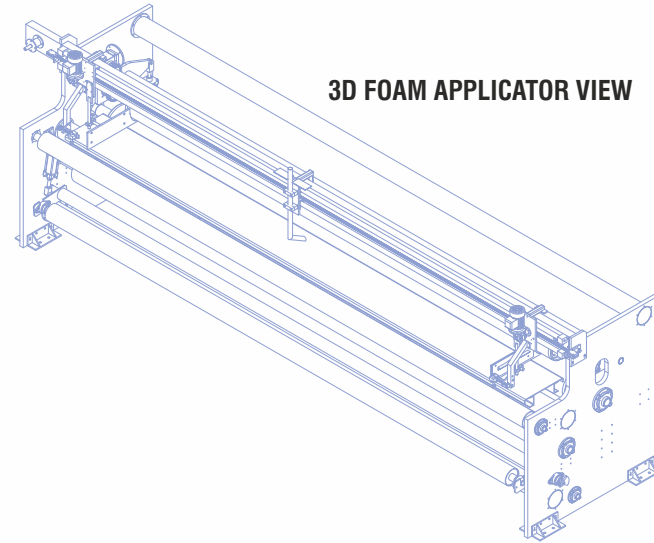

3D FOAM APPLICATOR VIEW

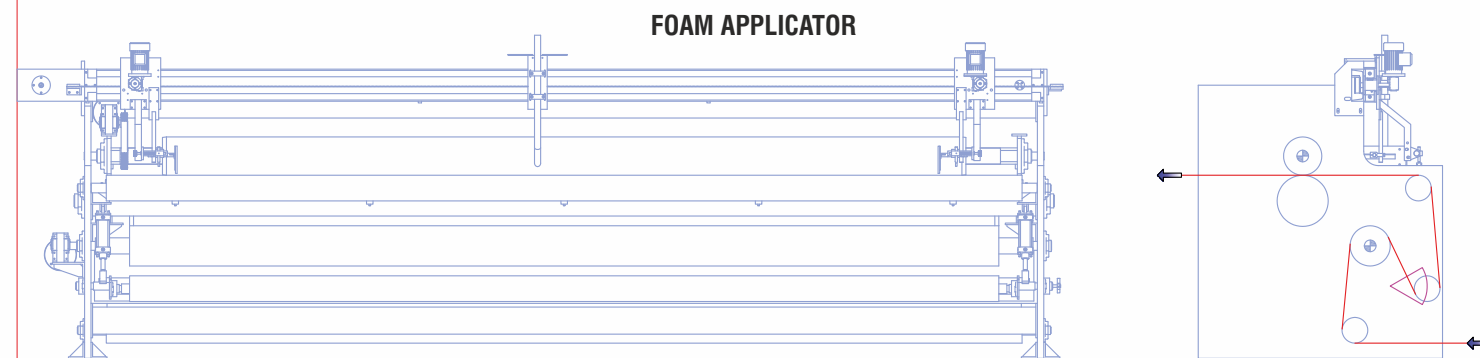

FOAM APPLICATOR

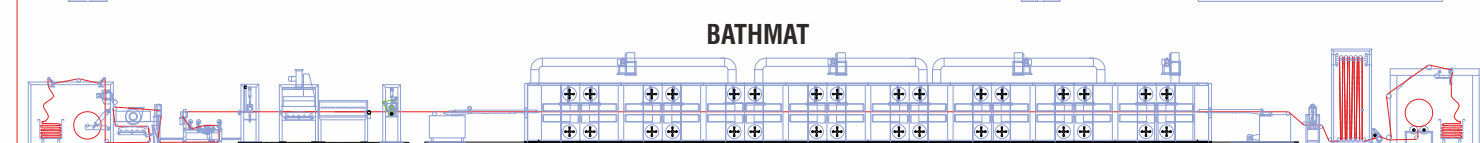

BATHMAT

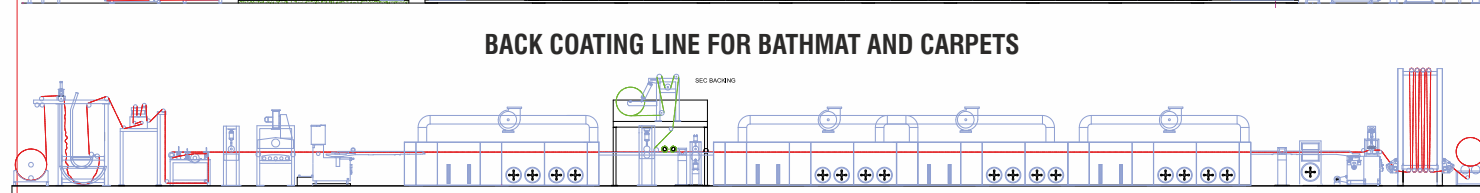

BACK COATING LINE FOR BATHMAT AND CARPETS

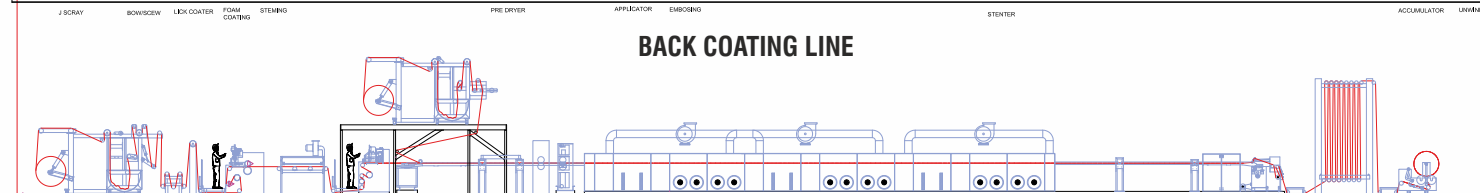

BACK COATING LINE

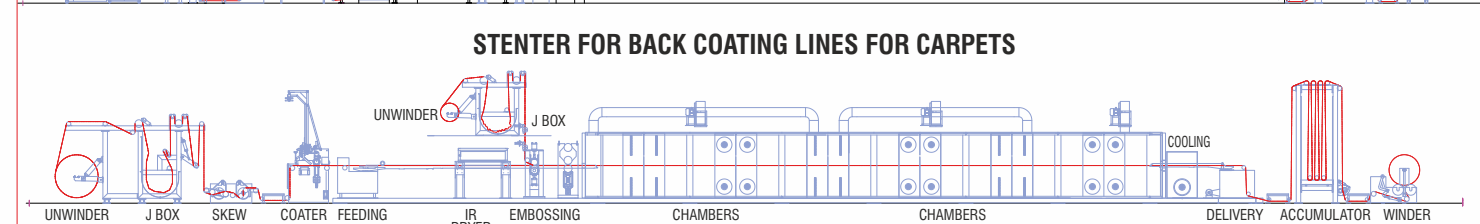

STENTER FOR BACK COATING LINES FOR CARPETS

BATHMAT & CARPETS





DIPING LINES

DIPING LINE-1850MM-REV11

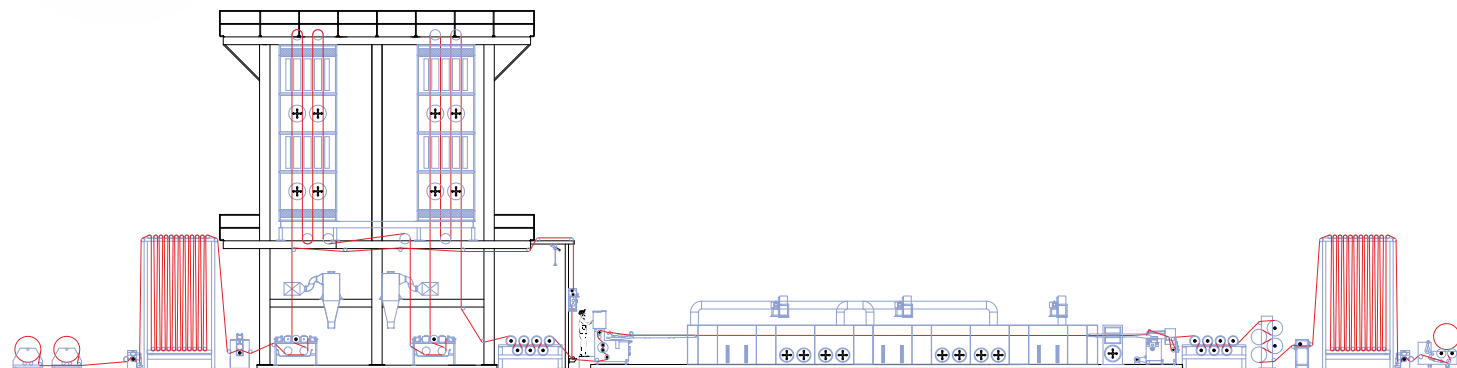

DIPPING LINE MADURA-1800MM

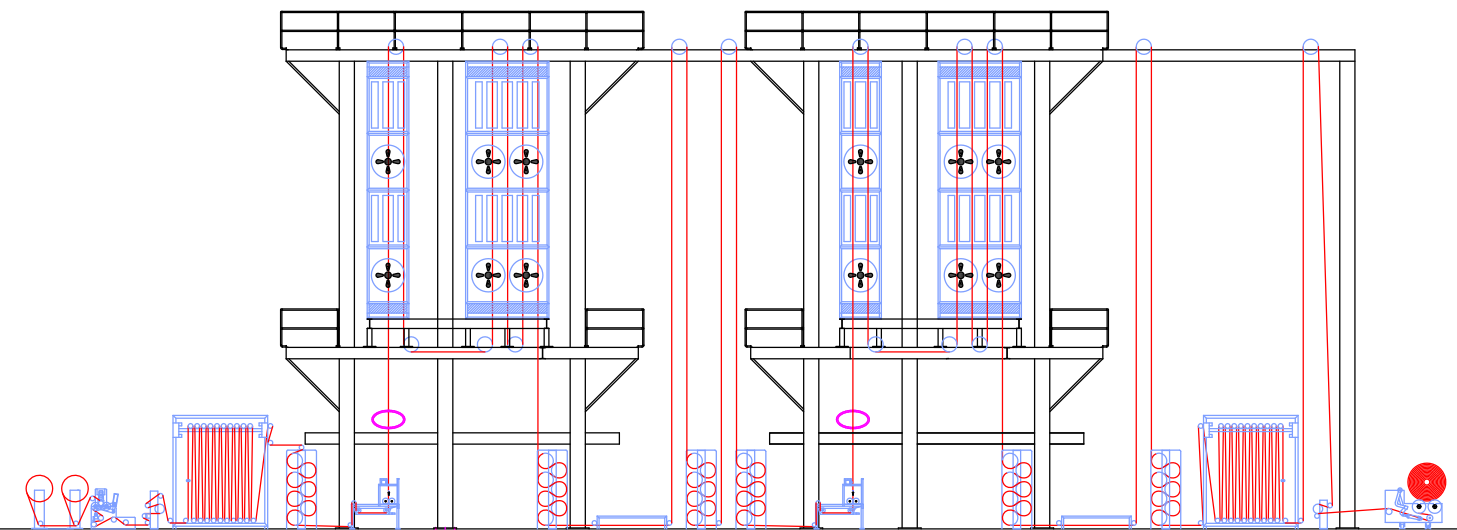

GA OF GLASS FIBER COATING LINE

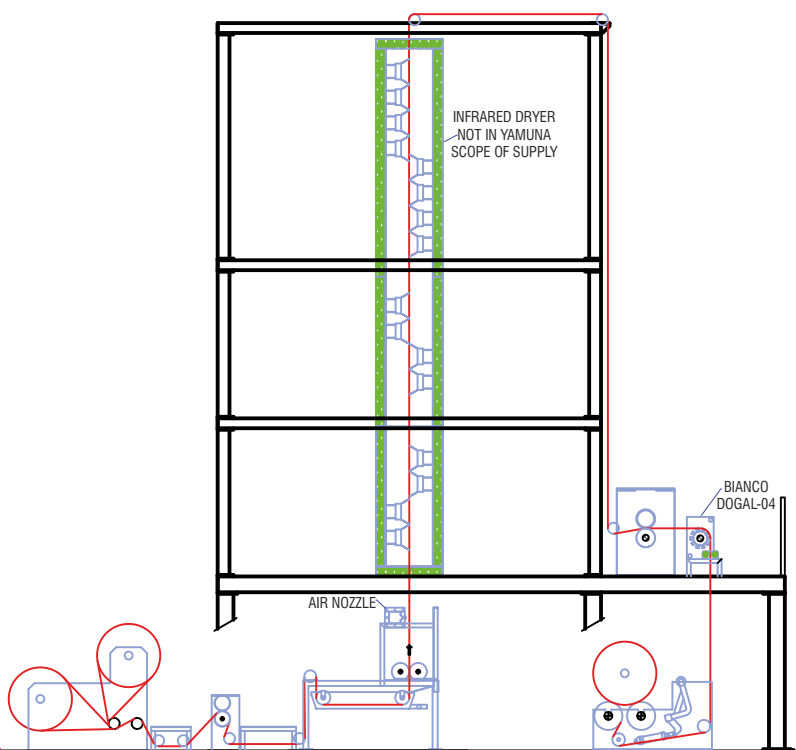

Technical specification.

- All the rollers in Dipping unit are positive driven.
- All the rollers in dryer are positive drive.
- Pyrometers must used for all chambers for moisture controlling.
- The chamber blowers must be in LEFT & RIGHT direction or one side depend on application.
- PROXIMITY SWITCH control to fire the burner on exhaust system.
- Load cell or measuring device is installed for tension control.
- All the rollers in accumulator (top & bottom) are positive driven.
- Normal servo motor to be used for center winder drive.
- Heating methods: steam, oil, gas & electrical
- Product width : 2,200mm TO 4,200mm or according to customers' requirements.



DIPING LINES

Vertical Dryer - Dipping Machine

- Dipping Lines for nylon & polyester fabric for tyre cord fabrics, belting and canvas are supplied with vertical dryer and stenter.
- Vertical dryer are either 2 pass or 4 pass. Each pass can have either impingement of air on 1 side or on both sides.
- Slit type nozzles are provided for uniform air pressure and temperature.
- This can be provided with oil heating or direct gas fire.
- Central exhaust system is provided through and within vertical dryer, which can also be used for quick pool.

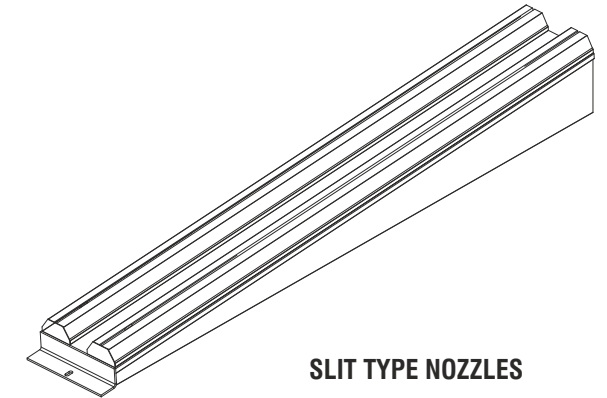

SLIT TYPE NOZZLES





NON WOVENS

INTRODUCTION TO NONWOVENS

Applications Of Nonwovens

Nonwovens find numerous applications ranging from baby diapers to industrial high performance textiles. Some of the important areas where nonwovens are treated as primary alternative for traditional textiles are Geotextiles, materials for building, thermal and sound insulating materials, hygienic and health care textiles and automotive industries. Nonwovens are also used in cover stocks, agriculture, aerospace, home furnishings etc. Although it is not possible to list all the applications of nonwovens, some of the important applications are listed below.

Features And Specification of Dryer

- Variable air flow for top and bottom on fabric.
- Hot air penetration and convection with high heat efficiency
- Heating methods: steam, oil, gas & electrical
- Product width : 2,200mm TO 4,200mm or according to customers' requirements.
- Product specification: 40 - 400gsm

NONWOVENS PRODUCTS

- | | | | |
|--|---|---|--|
| <ul style="list-style-type: none"> • Agriculture and Landscaping <ul style="list-style-type: none"> Crop Covers Turf protection products Nursery overwintering Weed control fabrics Root bags Containers Capillary matting • Automotive <ul style="list-style-type: none"> Trunk applications Floor covers Side liners Front and back liners Wheelhouse covers Rear shelf trim panel covers Seat applications Listings Cover slip sheets Foam reinforcements Transmission oil filters Door trim panel carpets Door trim panel padding Vinyl, landau cover backings Molded headliner substrates Hood silencer pads Dash insulators Carpet tufting fabric and under padding • Clothing <ul style="list-style-type: none"> Interlinings Clothing and glove insulation Bra and shoulder padding Handbag components Shoe components • Construction <ul style="list-style-type: none"> Roofing and tile underlayment Acoustical ceilings Insulation House wrap | <ul style="list-style-type: none"> Pipe wrap • Geotextiles <ul style="list-style-type: none"> Asphalt overlay Road and railroad beds Soil stabilization Drainage Dam and stream embankments Golf and tennis courts Artificial turf Sedimentation and erosion control Pond liners • Home Furnishings <ul style="list-style-type: none"> Furniture construction sheeting Insulators, arms and back Cushion ticking Decking Skirt linings Pull strips Bedding construction sheeting Quilt backing Dust covers Flanging Spring wrap Insulators Quilt backings Blankets Wallcovering backings Acoustical wallcoverings Upholstery backings Pillows, pillow cases Window treatments Drapery components Carpet backings, carpets, and Pads Mattress pad components • Health Care <ul style="list-style-type: none"> Surgical: caps, gowns, masks, Shoe covers | <ul style="list-style-type: none"> Sponges, dressings, wipes Orthopedic padding Bandages, tapes Dental bibs Drapes, wraps, packs Sterile packaging Bed linen, underpads Contamination control gowns Electrodes Examination gowns Filters for IV solutions, blood Oxygenators and kidney Dialyzers Transdermal drug delivery | <ul style="list-style-type: none"> Lubricating pads Flame barriers Packaging Conveyor belts Display felts Papermaker felts Noise absorbent felt |
|--|---|---|--|

NON WOVENS





NON WOVENS

8 CY DRYING RANGE WITH DRUM DRYER

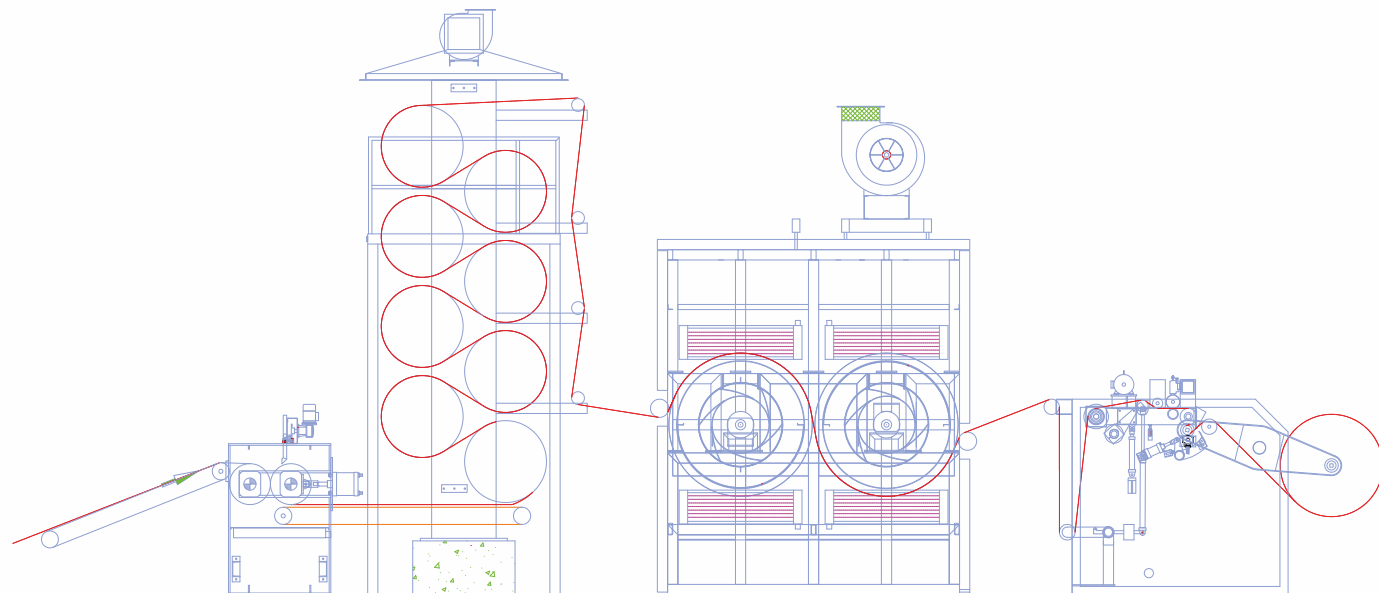

BACK COATING LINE

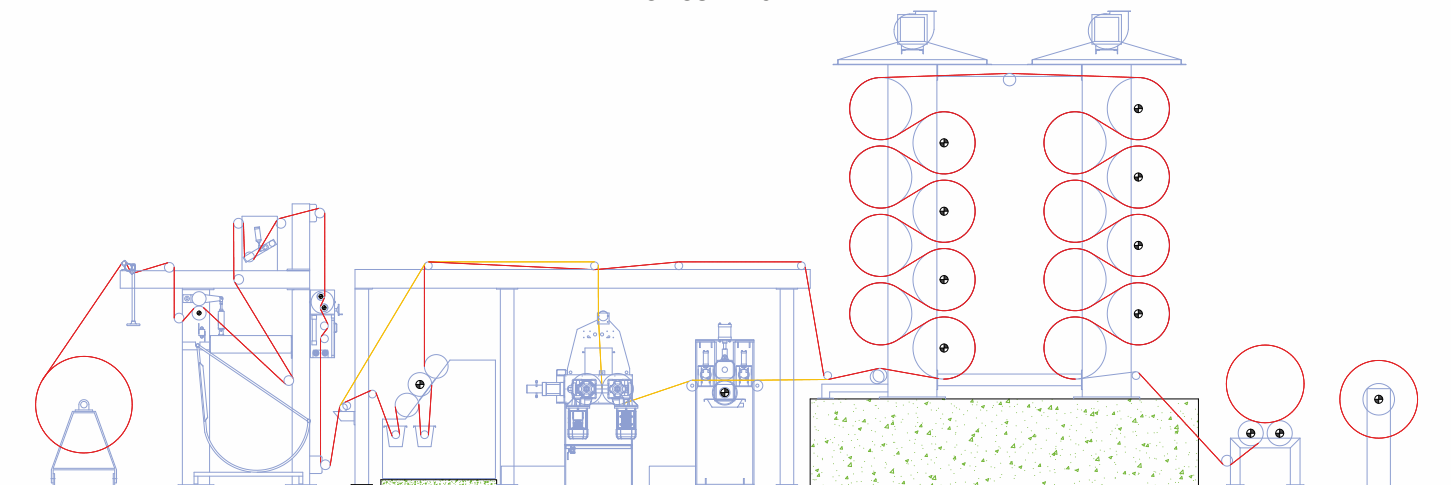

DRYING RANGE NON-WOVEN

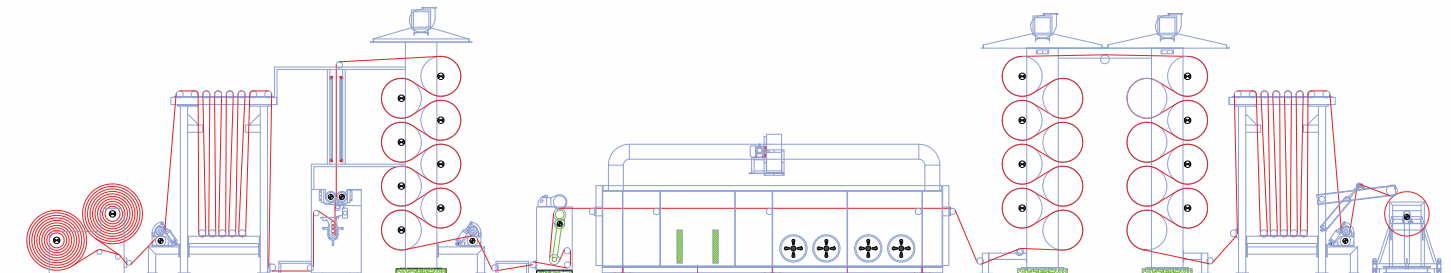

3CHAMBER THERMOBONDING

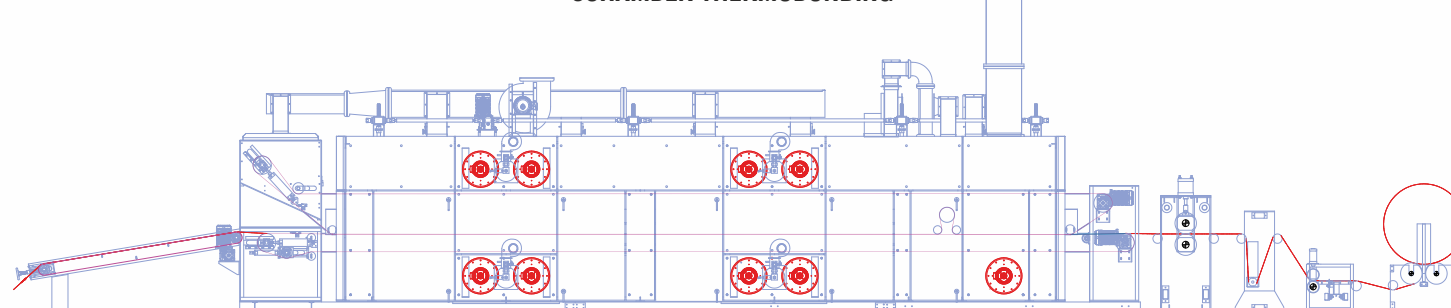

NON WOVENS



CALANDER UNIT

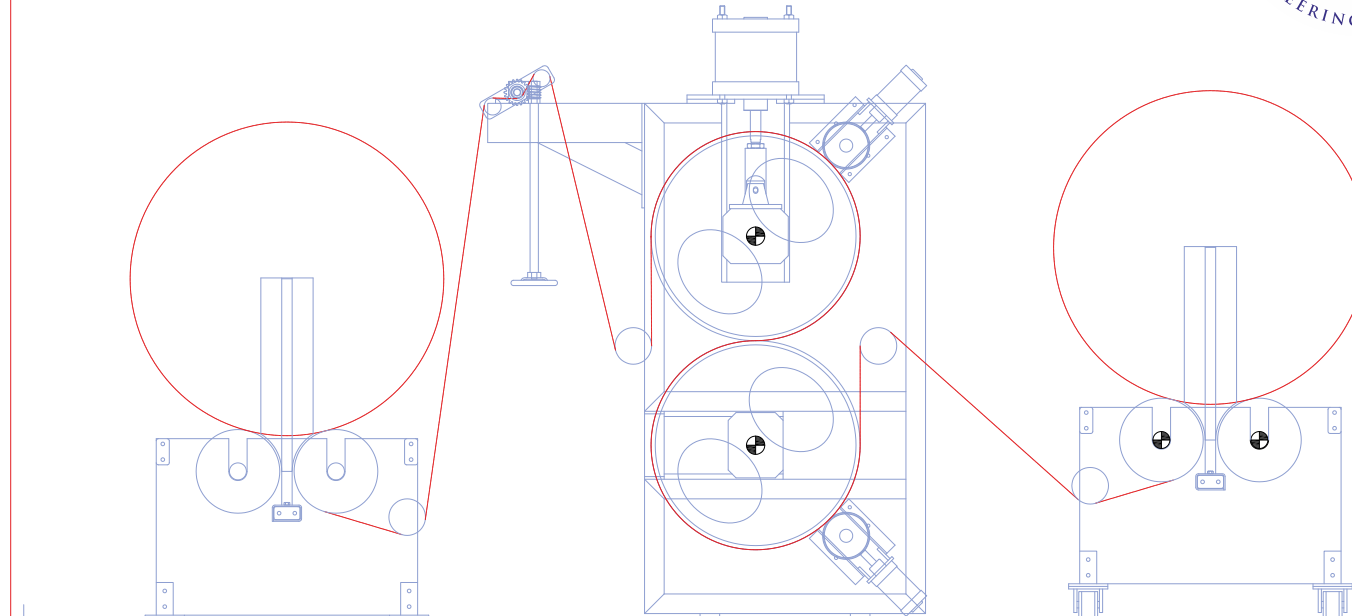

COATING PLAN

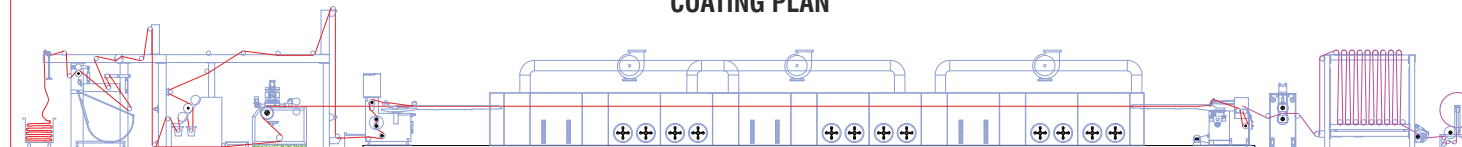

POWER SCATERING UNIT

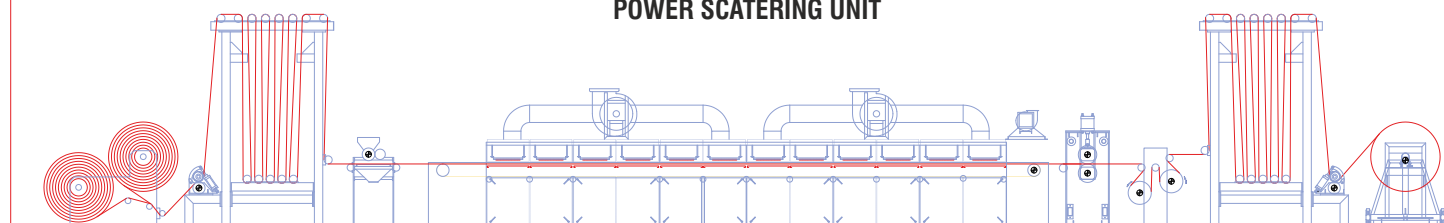

SATURATOR LINE

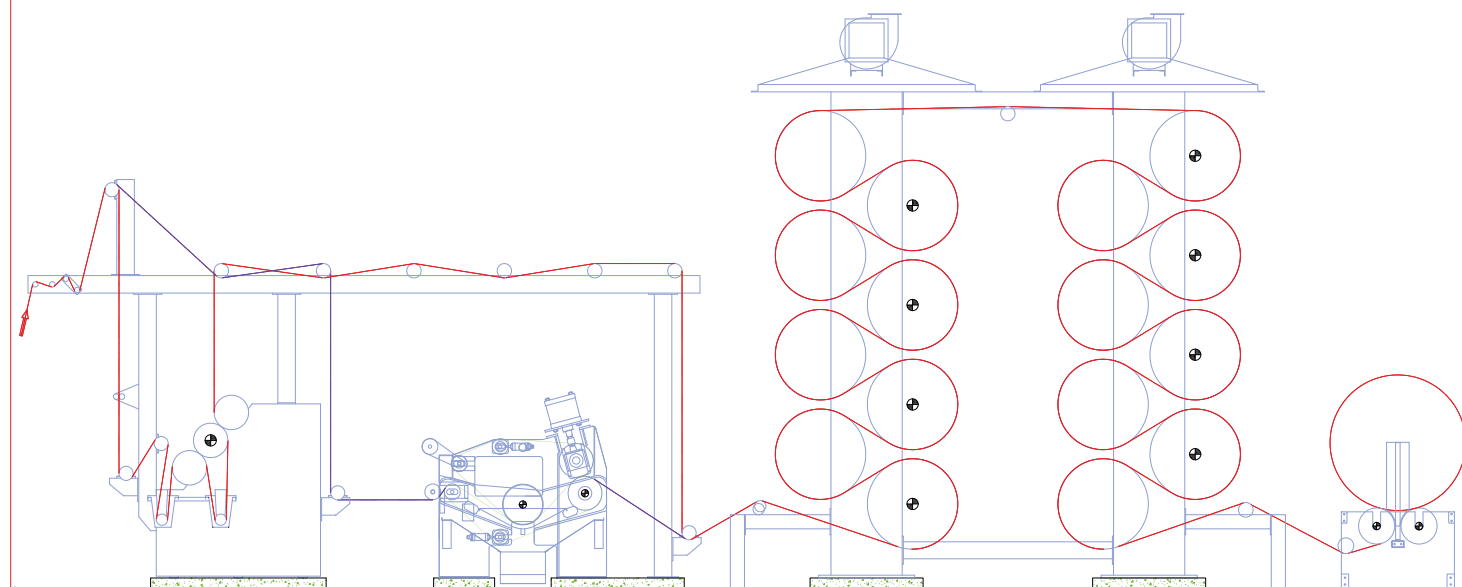



POPULAR WORLD OVER

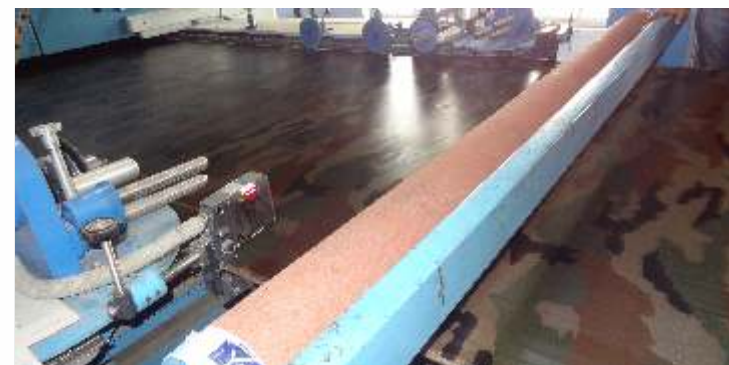
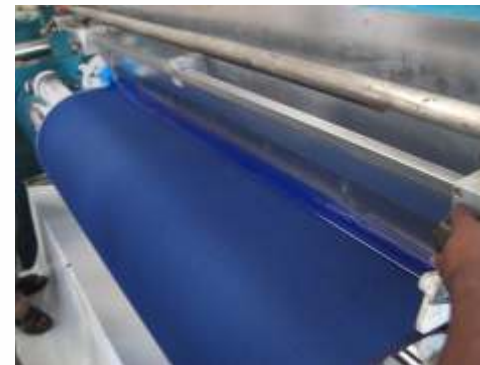

PRODUCT RANGE



Hot Air Stenter



Jigger



Coating Head



Singeing Machine



Drying Range



Polymeriser / Curing



Dye Pedder



Drum Dryer



Thermobonding Line



Relax Dryer



Shrinking Range



Merceriser



Denim Finishing Range



Pad steam / Washing Range



Dipping Line & Technical Textile